

**11220 HYUNDAI ELANTRA**

**GROSS LOAD CAPACITY WHEN USED AS A WEIGHT CARRYING HITCH: 2000 LBS. TRAILER WEIGHT & 200 LBS. TONGUE WEIGHT. \*\*\*DO NOT EXCEED VEHICLE MANUFACTURER'S RECOMMENDED TOWING CAPACITY.\*\*\***

Parts List			
ITEM	QTY	PART NUMBER	DESCRIPTION
1	1	D-55001	1 1/4" CURT BALL MOUNT
2	1	F-4	1/2" DIA. PIN & CLIP
3	2	M10 - 1.25 x 40 HEX	HEX BOLT
4	2	7/16	WASHER
5	2	7/16	HELICAL LOCK WASHER
6	1	1/2"	LOCK WASHER
7	1	1/2-13	HEX NUT
8	1	1/2-13 x 1 3/4	CARRIAGE BOLT
9	1	CM-SP4	.250 x 1.50 x 3.00" SQUARE HOLE SPACER

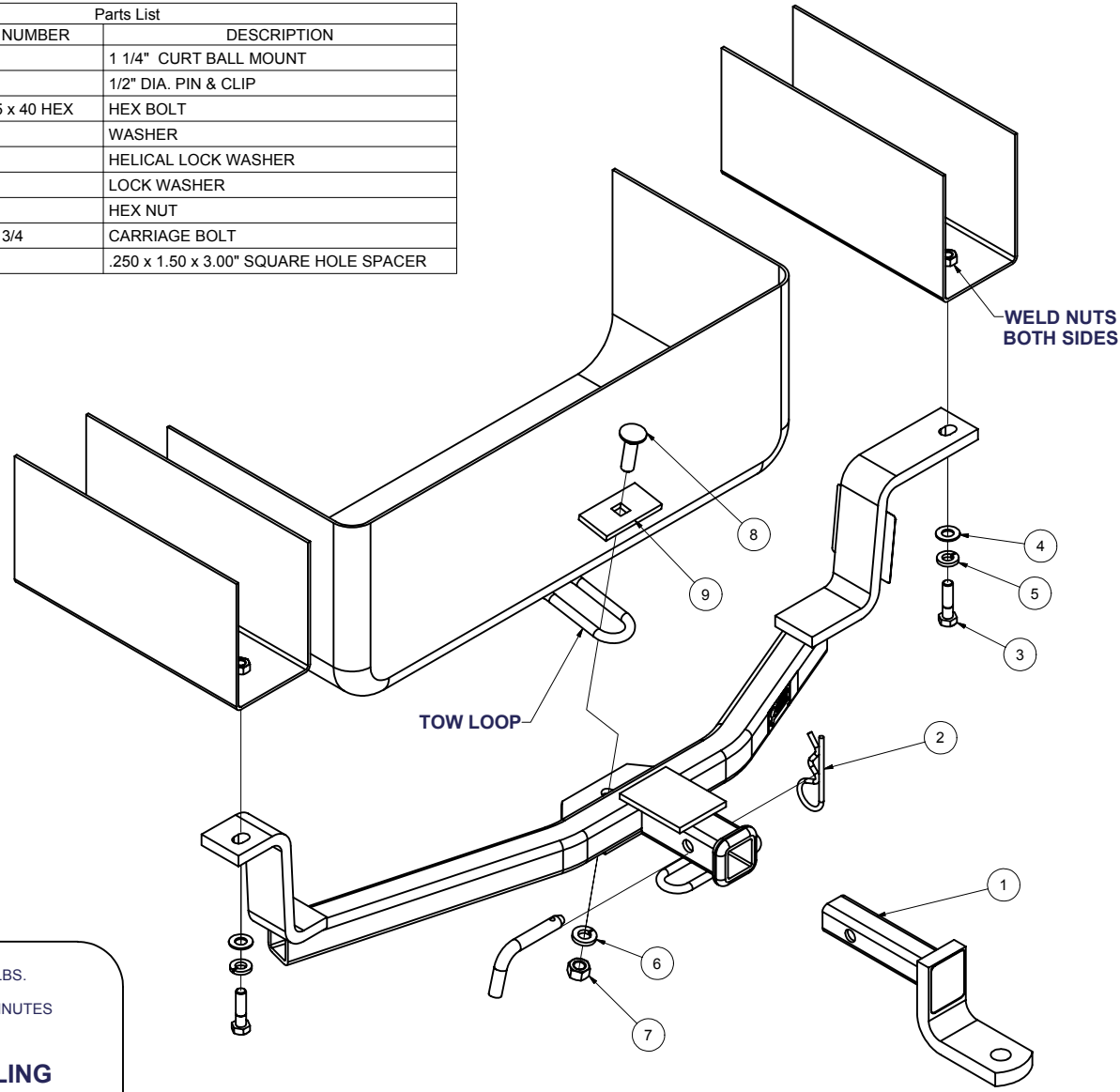

HITCH WEIGHT: 21.5 LBS.  
 INSTALL TIME: 10 MINUTES  
 INSTALL NOTES:  
**NO DRILLING  
 REQUIRED**

**INSTALLATION STEPS**

- 1) Remove existing M10 bolts from weld nuts in frame.
- 2) Using the new fasteners provided, fasten the hitch to the frame. Do not tighten.
- 3) Attach the hitch to the tow loop with the 1/2" hardware and the tow loop plate as shown.
- 4) Tighten all bolts to the following specifications:

M10 = 37 ft-lbs  
 1/2" = 75 ft-lbs

**PERIODICALLY CHECK THIS RECEIVER HITCH TO INSURE THAT ALL FASTENERS ARE TIGHT AND THAT ALL STRUCTURAL COMPONENTS ARE SOUND.**

Curt Manufacturing Inc., warrants this product to be free of defects in material and/or workmanship at the time of retail purchase by the original purchaser. If the product is found to be defective, Curt Manufacturing Inc., may repair or replace the product, at their option, when the product is returned, prepaid, with proof of purchase. Alteration to, misuse of, or improper installation of this product voids the warranty. Curt Manufacturing Inc.'s liability is limited to repair or replacement of products found to be defective, and specifically excludes liability for incidental or consequential loss or damage.