



10/31/2006

11228

HYUNDAI XG300

GROSS LOAD CAPACITY WHEN USED AS A WEIGHT CARRYING HITCH: 2,000 LBS. TRAILER WEIGHT & 200 LBS. TONGUE WEIGHT.
*****DO NOT EXCEED VEHICLE MANUFACTURER'S RECOMMENDED TOWING CAPACITY.*****

Parts List			
ITEM	QTY	PART NUMBER	DESCRIPTION
1	1	1/2-13 x 1 3/4	HEX BOLT
2	1	1/2"	LOCK WASHER
3	1	1/2-13	HEX NUT
4	2	M10 - 1.25 x 40 HEX	HEX BOLT
5	2	3/8"	WASHER
6	2	7/16	HELICAL LOCK WASHER
7	1	D-55001	1 1/4" CURT BALL MOUNT
8	1	F-4	1/2" DIA. PIN & CLIP
9	1	CM-SP51	.250 x 1.50 x 3.00" ROUND HOLE SPACER

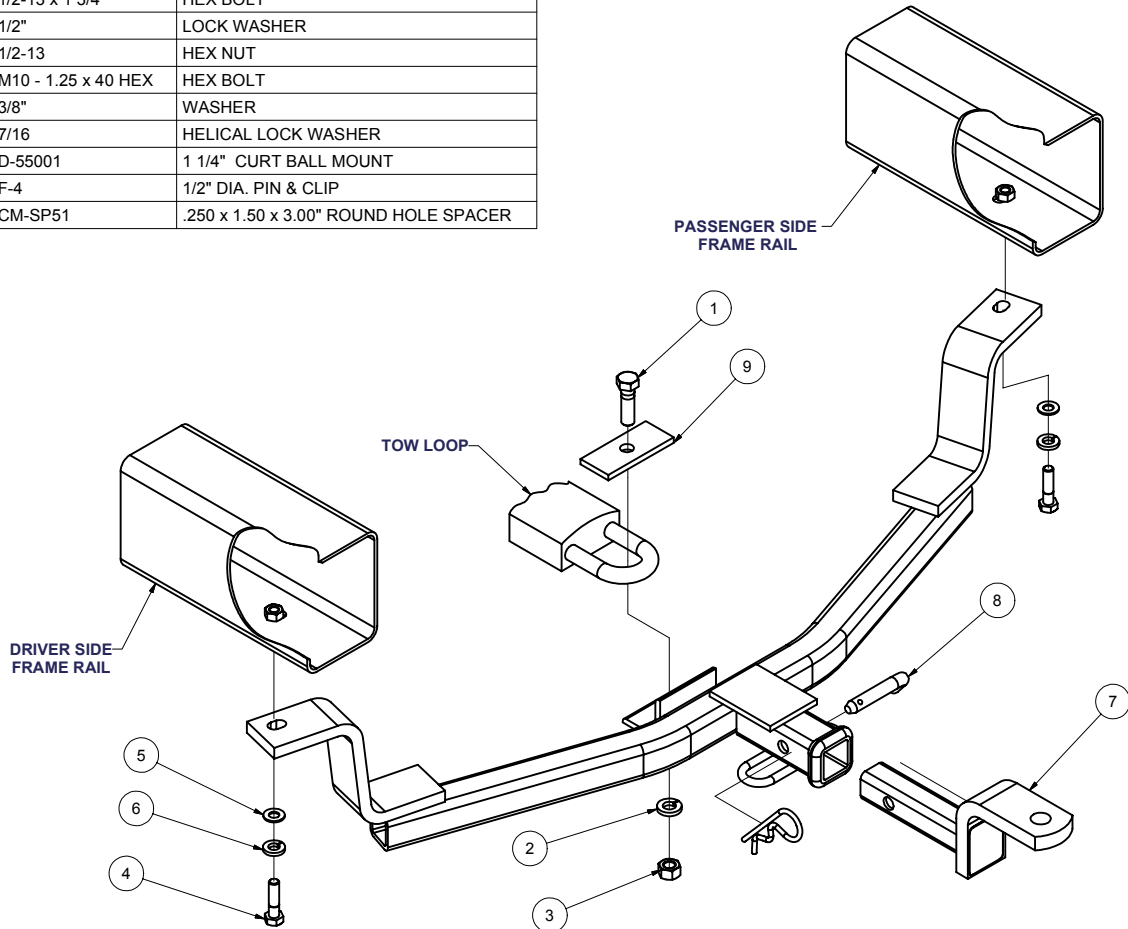
HITCH WEIGHT: 22 LBS.INSTALL TIME: 45 MINUTES

INSTALL NOTES:

NO DRILLING REQUIRED**INSTALLATION STEPS**

- 1) This hitch mounts to the bottom of the right and left frame rails; one threaded hole each side, and to the tow loop located on the car's trunk pan.
- 2) Temporarily lower the muffler/tail pipe by disconnecting the two rearmost hangers if necessary.
- 3) Lift the hitch into position on the bottom of the frame rails, as shown in the diagram. Install as shown. Do not fully tighten.
- 4) Fasten the hitch to the tow loop using fasteners as shown. The backing plate fits to the top of the loop and the hitch bracket fits under the loop.
- 5) Torque all 1/2" fasteners to 75 lb-ft, and all 10mm fasteners to 36 lb-ft.

PERIODICALLY CHECK THIS RECEIVER HITCH TO ENSURE THAT ALL FASTENERS ARE TIGHT AND THAT ALL STRUCTURAL COMPONENTS ARE SOUND.

Curt Manufacturing Inc., warrants this product to be free of defects in material and/or workmanship at the time of retail purchase by the original purchaser. If the product is found to be defective, Curt Manufacturing Inc., may repair or replace the product, at their option, when the product is returned, prepaid, with proof of purchase. Alteration to, misuse of, or improper installation of this product voids the warranty. Curt Manufacturing Inc.'s liability is limited to repair or replacement of products found to be defective, and specifically excludes liability for incidental or consequential loss or damage.