



12530

RX330 / RX300 / RX400H
HIGHLANDER / HIGHLANDER HYBRID

GROSS LOAD CAPACITY WHEN USED AS A WEIGHT CARRYING HITCH: 3,500 LBS. TRAILER WEIGHT & 350 LBS. TONGUE WEIGHT.
*****DO NOT EXCEED VEHICLE MANUFACTURER'S RECOMMENDED TOWING CAPACITY.*****

Parts List			
ITEM	QTY	PART NUMBER	DESCRIPTION
1	6	M10 - 1.25 x 30	HEX BOLT
2	6	3/8"	CONICAL TOOTHED WASHER

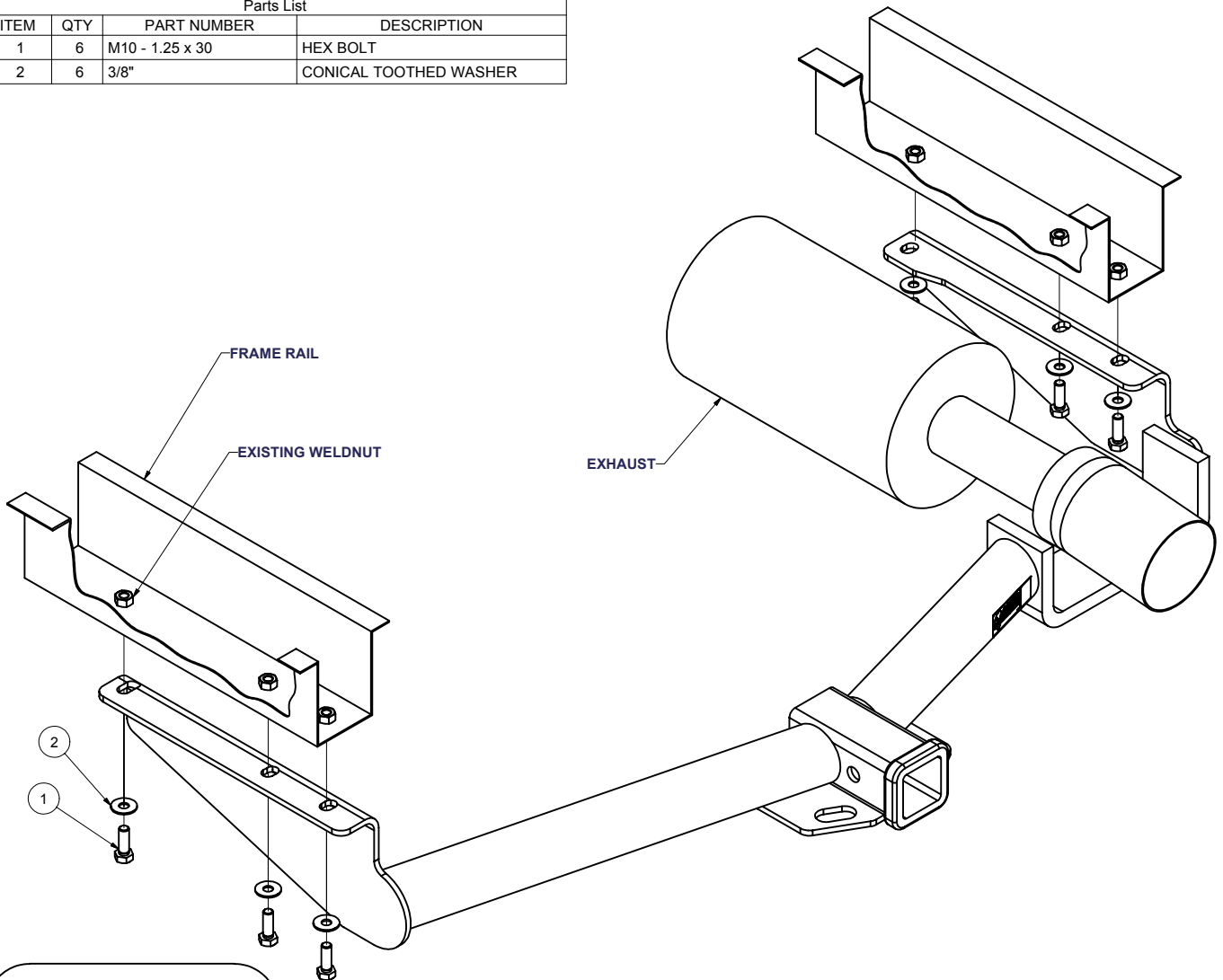

HITCH WEIGHT: 40 LBS.
INSTALL TIME: 20 MINUTES
INSTALL NOTES:
REMOVE TIE DOWN BRACKETS

INSTALLATION STEPS

- 1) Remove tie down brackets if present.
- 2) Maneuver passenger side plate around the exhaust and hold hitch up against frame.
- 3) Align hitch mounting holes to existing weldnuts in frame. Install M10 bolts and conical washers as shown.
- 4) Torque all M10 fasteners to 36 lb.-ft.

PERIODICALLY CHECK THIS RECEIVER HITCH TO INSURE THAT ALL FASTENERS ARE TIGHT AND THAT ALL STRUCTURAL COMPONENTS ARE SOUND.

Curt Manufacturing Inc., warrants this product to be free of defects in material and/or workmanship at the time of retail purchase by the original purchaser. If the product is found to be defective, Curt Manufacturing Inc., may repair or replace the product, at their option, when the product is returned, prepaid, with proof of purchase. Alteration to, misuse of, or improper installation of this product voids the warranty. Curt Manufacturing Inc.'s liability is limited to repair or replacement of products found to be defective, and specifically excludes liability for incidental or consequential loss or damage.