



13701

ADJUSTABLE RV HITCH

GROSS LOAD CAPACITY WHEN USED AS A WEIGHT CARRYING HITCH: 5,000 LBS. TRAILER WEIGHT & 500 LBS. TONGUE WEIGHT
 GROSS LOAD CAPACITY WHEN USED AS A WEIGHT DISTRIBUTION HITCH: 6,000 LBS. TRAILER WEIGHT & 600 LBS. TONGUE WEIGHT
 DO NOT EXCEED VEHICLE BUMPER GROSS TOWING CAPACITY, OR USE WITH WEIGHT DISTRIBUTION EQUIPMENT.

Parts List			
ITEM	QTY	PART NUMBER	DESCRIPTION
1	4	1/2-13 x 1 1/2	CARRIAGE BOLT
2	4	1/2 - 13	HEX FLANGE NUT
3	1	1/2"	FISHWIRE TOOL
4	4	5/8	WASHER
5	4	5/8-11	HEX FLANGE NUT
6	4	5/8-11 x 1 1/2	HEX BOLT
7	4	CM-SP1	1.5 x 2 x .250 INSTALLATION SPACER

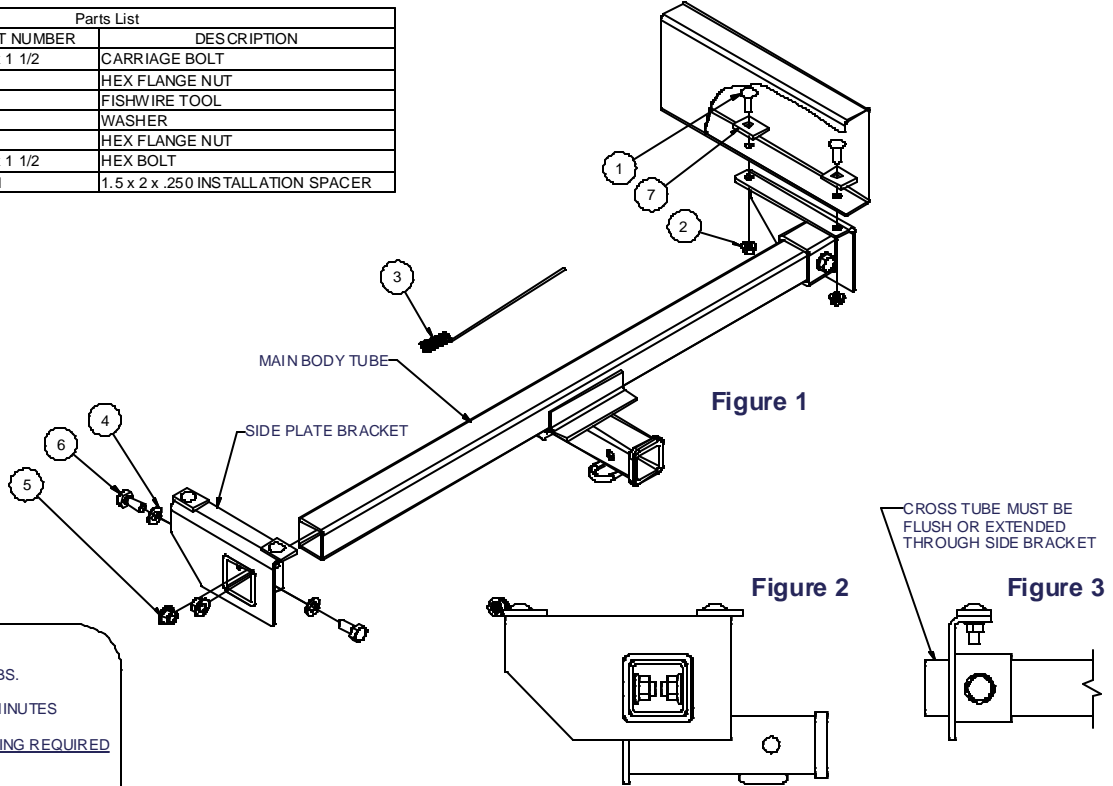

HITCH WEIGHT: 45 LBS.
 INSTALL TIME: 30 MINUTES
 INSTALL NOTES: DRILLING REQUIRED

INSTALLATION STEPS

THIS IS A GENERAL APPLICATION PRODUCT AND IT IS THE RESPONSIBILITY OF THE INSTALLER TO SELCT A STRUCTURALLY SAFE LOCATION FOR ATTACHMENT

- 1) Slide side plate brackets onto main body tube as shown.
- 2) Position and clamp side brackets to bottom of frame so the receiver tube with ballmount is centered on vehicle. Be sure to provide adequate coupler clearance.
- 3) Using side bracket as a template, drill two holes into frame using a 9/16 drill bit each side.
- 4) Install 1/2" carriage bolts and spacers through drilled holes in frame and side brackets. If access holes are not present, bolts and spacers may need to be fishwired into frame and/or bumper may need to be loosened for bolt and spacer installation. Loosely install 1/2" flange nuts and remove clamps.
- 5) Center the main body on vehicle and clamp at both ends to prevent movement while drilling. Drill 11/16 diameter holes through walls of cross tube using the two holes per side (total of four) in the side plate bracket tubes as templates. Install 5/8" hex bolts and flat washer into holes. From inside main body tube, place flange nut onto 5/8 hex bolt and remove clamps.
- 6) Main body tube may be trimmed flush with outside of side plate bracket. (Note: If trimmed flush, coat bare metal with paint to prevent corrosion.
- 7) Torque 1/2" hardware to 75 lb-ft, and 5/8" hardware to 150 lb-ft.

PERIODICALLY CHECK THIS RECEIVER HITCH TO INSURE THAT ALL FASTENERS ARE TIGHT AND THAT ALL STRUCTURAL COMPONENTS ARE SOUND.

Curt Manufacturing Inc., warrants this product to be free of defects in material or workmanship at the time of retail purchase by the original purchaser. If the product is found to be defective, Curt Manufacturing Inc., may repair or replace the product, at their option, when the product is returned, prepaid, with proof of purchase. Alteration to, misuse of, or improper installation of this product voids the warrant. Curt Manufacturing Inc.'s liability is limited to repair or replacement of products found to be defective, and specifically excludes liability for incidental or consequential loss or damage.