

GROSS LOAD CAPACITY WHEN USED AS A WEIGHT CARRYING HITCH: 2,000 LBS. TRAILER WEIGHT & 200 LBS. TONGUE WEIGHT.  
**\*\*\*DO NOT EXCEED VEHICLE MANUFACTURER'S RECOMMENDED TOWING CAPACITY.\*\*\***

Parts List			
ITEM	QTY	PART NUMBER	DESCRIPTION
1	4	7/16-14 x 1 1/4	HEX BOLT
2	4	7/16	HELICAL LOCK WASHER
3	4	7 16 - 14 FLANGE HANDLE NUT	HEX NUT
4	1	D-55001	1 1/4" CURT BALL MOUNT
5	1	F-4 PIN	HITCH PIN
6	1	F-4 CLIP	HITCH PIN CLIP

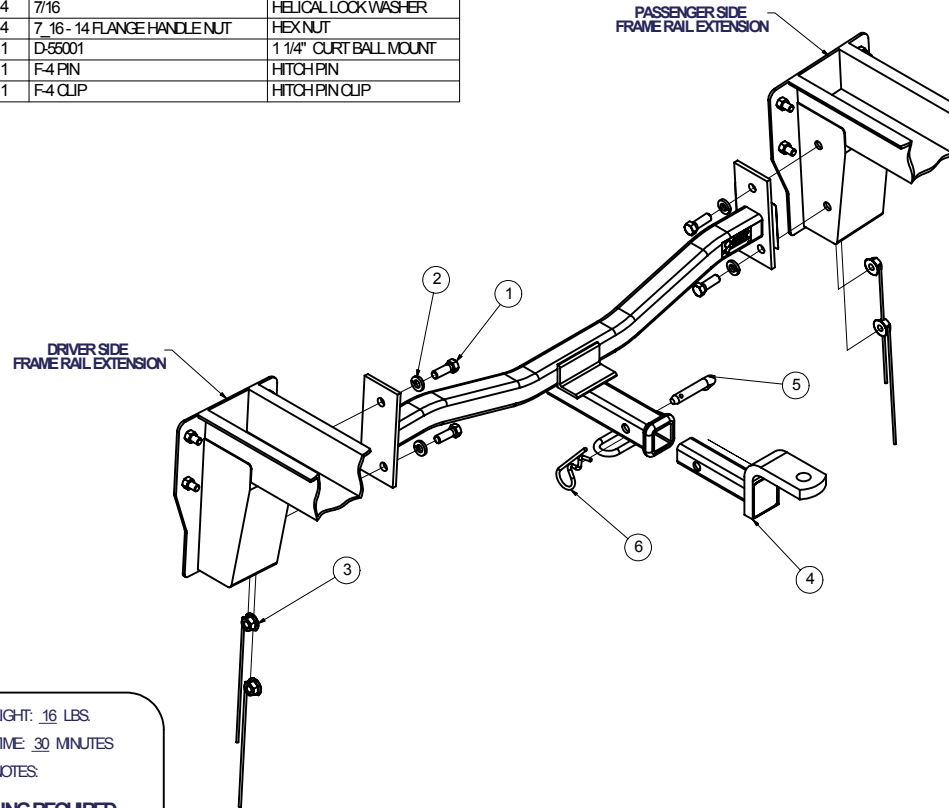

HITCH WEIGHT: 16 LBS.  
 INSTALL TIME: 30 MINUTES  
 INSTALL NOTES:

**DRILLING REQUIRED**

**INSTALLATION STEPS**

- 1) This hitch mounts to the inside surface of the left and right frame rail extensions.
- 2) Position the hitch up between the frame rail extensions, with the hitch plates as far forward as possible and flush at the bottom surface of the frame rail extensions. Using the hitch as a template, mark the centers of the holes to be drilled for fasteners as shown.
- 3) Remove the hitch and drill for fasteners.
- 4) Position the hitch on the vehicle matching the holes in the frame rail extensions with the holes in the hitch plates. Install fasteners as shown. Pass handle nuts up through the opening at the bottom of the frame rails extensions.
- 5) Torque all 7/16 fasteners to 35 lb-ft.

**PERIODICALLY CHECK THIS RECEIVER HITCH TO INSURE THAT ALL FASTENERS ARE TIGHT AND THAT ALL STRUCTURAL COMPONENTS ARE SOUND.**

Curt Manufacturing Inc. warrants this product to be free of defects in material and/or workmanship at the time of retail purchase by the original purchaser. If the product is found to be defective, Curt Manufacturing Inc. may repair or replace the product, at their option, when the product is returned, prepaid, with proof of purchase. Alteration, misuse of, or improper installation of this product voids the warranty. Curt Manufacturing Inc.'s liability is limited to repair or replacement of products found to be defective, and specifically excludes liability for incidental or consequential loss or damage.