

31313**TOYOTA TACOMA FRONT HITCH**

8/28/2009

GROSS LOAD CAPACITY WHEN USED AS A WEIGHT CARRYING HITCH: 3500 LBS. TRAILER WEIGHT & 350 LBS. TONGUE WEIGHT.

GROSS LOAD CAPACITY WHEN USED AS A STRAIGHT LINE PULL: 9,000 LBS. MAX. LINE PULL.

*****DO NOT EXCEED VEHICLE MANUFACTURER'S RECOMMENDED TOWING CAPACITY.*****

Parts List			
ITEM	QTY	PART NUMBER	DESCRIPTION
1	2	CM-SP3	.250 x 1.25 x 2.00" SQUARE HOLE SPACER
2	2	1/2-13 x 1 1/4	CARRIAGE BOLT
3	6	1/2 - 13	HEX FLANGE NUT
4	4	CM-SP4	.250 x 1.50 x 3.00" SQUARE HOLE SPACER
5	4	1/2-13 x 4	CARRIAGE BOLT
6	8	7/16-14 x 1 1/4	CARRIAGE BOLT
7	8	7/16-14	HEX FLANGE NUT

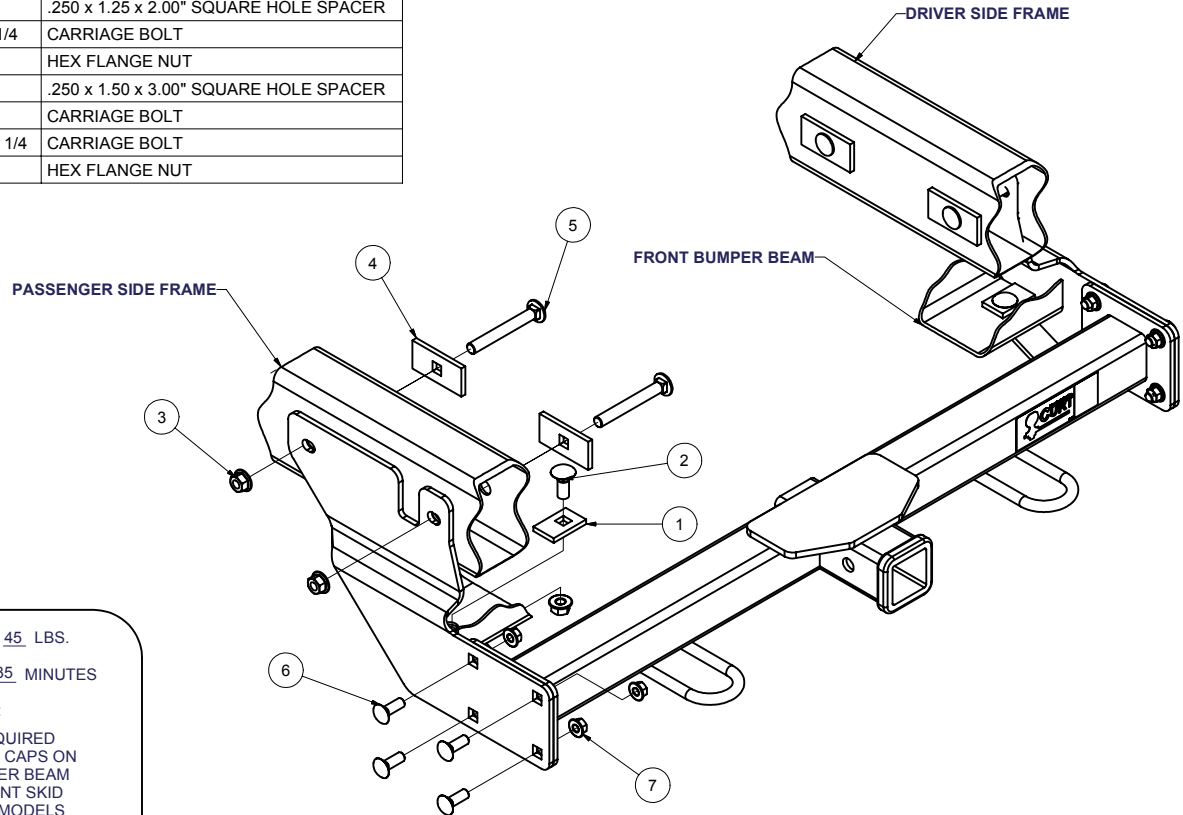

HITCH WEIGHT: 45 LBS.

INSTALL TIME: 35 MINUTES

INSTALL NOTES:

- NO DRILL REQUIRED
- REMOVE END CAPS ON FRONT BUMPER BEAM
- REMOVE FRONT SKID PLATE ON 07 MODELS AND NEWER

INSTALLATION STEPS

1. Remove 2 bolts, one from each end of front bumper beam. Pull out end caps and return to customer.
2. Place 4" carriage bolt through spacer(CM-SP4) and into existing holes from the inside of the frame (both sides).
3. Where the end cap was removed in step 1, place a 1/2" x 1 1/4" carriage bolt through spacer(CM-SP3) into the existing hole in the front bumper beam.
4. Hang side plates from carriage bolts installed in step 2 on the outside of the frames and finger tight with 1/2" flange nuts.
5. Lift main body into place between side plates and loosely attach using 7/16" carriage bolts and flange nuts as shown.
6. Attach straps of main body to 1/2" carriage bolts placed in step 3. Finger tight with 1/2" flange nuts.
7. Torque all 1/2" fasteners to 75 ft.-lbs. and 7/16" fasteners to 50 ft.-lbs. in the following order:
First: Fasten main body to side plates.
Second: Fasten strap to front bumper beam.
Third: Fasten side plates to frame.

PERIODICALLY CHECK THIS RECEIVER HITCH TO ENSURE THAT ALL FASTENERS ARE TIGHT AND THAT ALL STRUCTURAL COMPONENTS ARE SOUND.

Curt Manufacturing Inc., warrants this product to be free of defects in material and/or workmanship at the time of retail purchase by the original purchaser. If the product is found to be defective, Curt Manufacturing Inc., may repair or replace the product, at their option, when the product is returned, prepaid, with proof of purchase. Alteration to, misuse of, or improper installation of this product voids the warranty. Curt Manufacturing Inc.'s liability is limited to repair or replacement of products found to be defective, and specifically excludes liability for incidental or consequential loss or damage.

DO NOT EXCEED VEHICLE MANUFACTURER'S RECOMMENDED TOWING CAPACITY.

FRONT MOUNTED ACCESSORIES

1) Do not exceed front axle Gross Weight Rating (GAWR). Consult owners manual or specification plate located on driver's door frame. Measure gross front axle weight by placing front wheels of loaded vehicle on a scale.

WARNING: Exceeding GAWR may overload the front axle and/or suspension. This could result in **accident, property damage and personal injury.**

- 2) Reposition front mounted license plate if obstructed.
- 3) Do not obstruct vehicle lights.
- 4) Allow free air flow into grille opening.
- 5) Rear wheel traction may be reduced. This could effect handling. Reduce speed and drive with caution.
- 6) Accessories extend front of vehicle. This may reduce approach angle. Use caution when parking and maneuvering.
- 7) Do not obstruct driver view.

VEHICLE RECOVERY AND WINCHING TIPS

1) Use OEM tow hooks, recovery eyes or a clevis mount for attachment of a tow strap or winch cable.

WARNING: NEVER use a ball and/or ball mount as an anchor point for tow strap or winch cable. Severe personal injury or death could result.

- 2) Observe winch manufacturer's recommendations, cautions and warnings.
- 3) Attach return cable to tow hook or recovery eye when using a snatch block (See figure 1).

CAUTION: Do not attach return cable to winch mount. This may overload winch mount and/or front mounted receiver.

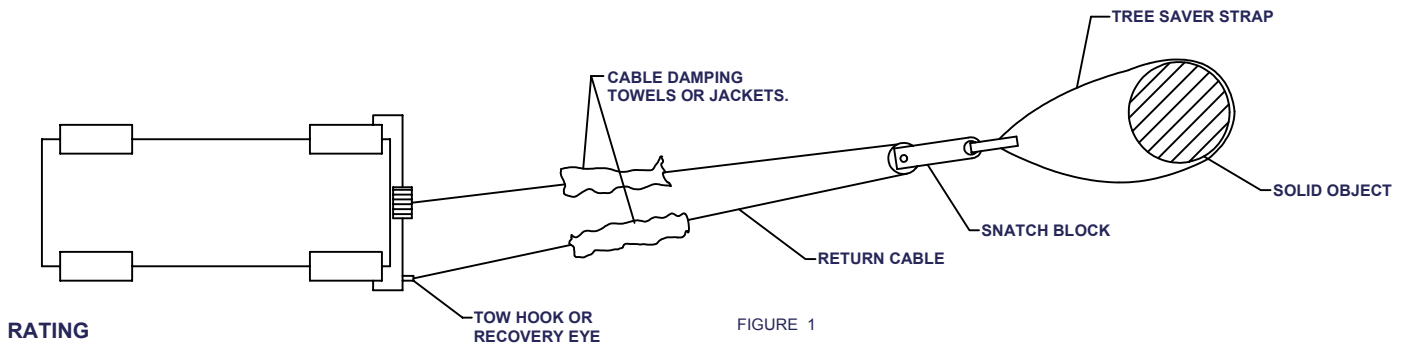

RATING

For **Maximum** line pull rating, winch cable must not exceed:

- 15 degree angle up or down from horizontal (See Figure 2).
- 45 degree angle left or right from straight ahead (See Figure 3).

CAUTION: Exceeding the maximum line pull rating may over load winch, winch mount, and/or front mounted receiver.

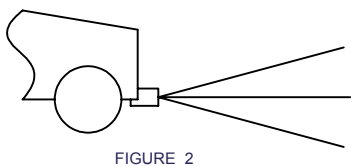

FIGURE 2

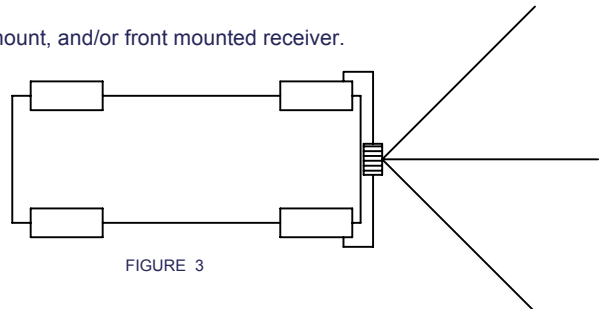

FIGURE 3