

13591

2004 - CURRENT CHEVY EQUINOX / GMC TERRAIN / 2004 - 2007 SATURN VUE REDLINE
2001 - 2007 SATURN VUE / 2006 - 2009 PONTIAC TORRENT

9/25/2009

GROSS LOAD CAPACITY WHEN USED AS A WEIGHT CARRYING HITCH: 3,500 LBS. TRAILER WEIGHT & 350 LBS. TONGUE WEIGHT.
GROSS LOAD CAPACITY WHEN USED AS A WEIGHT DISTRIBUTION HITCH: 4,000 LBS. TRAILER WEIGHT & 400 LBS. TONGUE WEIGHT*****DO NOT EXCEED VEHICLE MANUFACTURER'S RECOMMENDED TOWING CAPACITY.*****

HAVING INSTALLATION QUESTIONS? CALL TECHNICAL SUPPORT AT 1-800-798-0813

Parts List			
ITEM	QTY	PART NUMBER	DESCRIPTION
1	6	M12-1.75 x 40mm	HEX BOLT
2	6	1/2"	CONICAL TOOTHED WASHER
3	2	1/2-13 x 1 3/4	CARRIAGE BOLT
4	2	CM-SP1	.250 x 1.50 x 2.00" SQUARE HOLE SPACER
5	2	HFN 1213	HEX FLANGE NUT
6	1	1_2 x 30 FISHWIRE	1/2" x 30" FISHWIRE

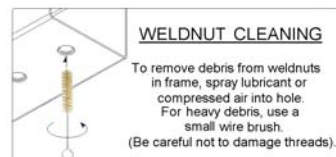
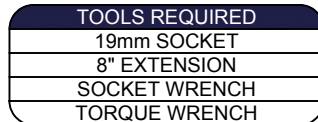
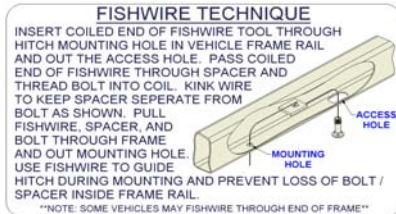

HITCH WEIGHT: 28 LBS.

INSTALL TIME

PROFESSIONAL: 30 MINUTES

NOVICE (DIY): 60 MINUTES

INSTALL NOTES:

NO DRILLING REQUIRED

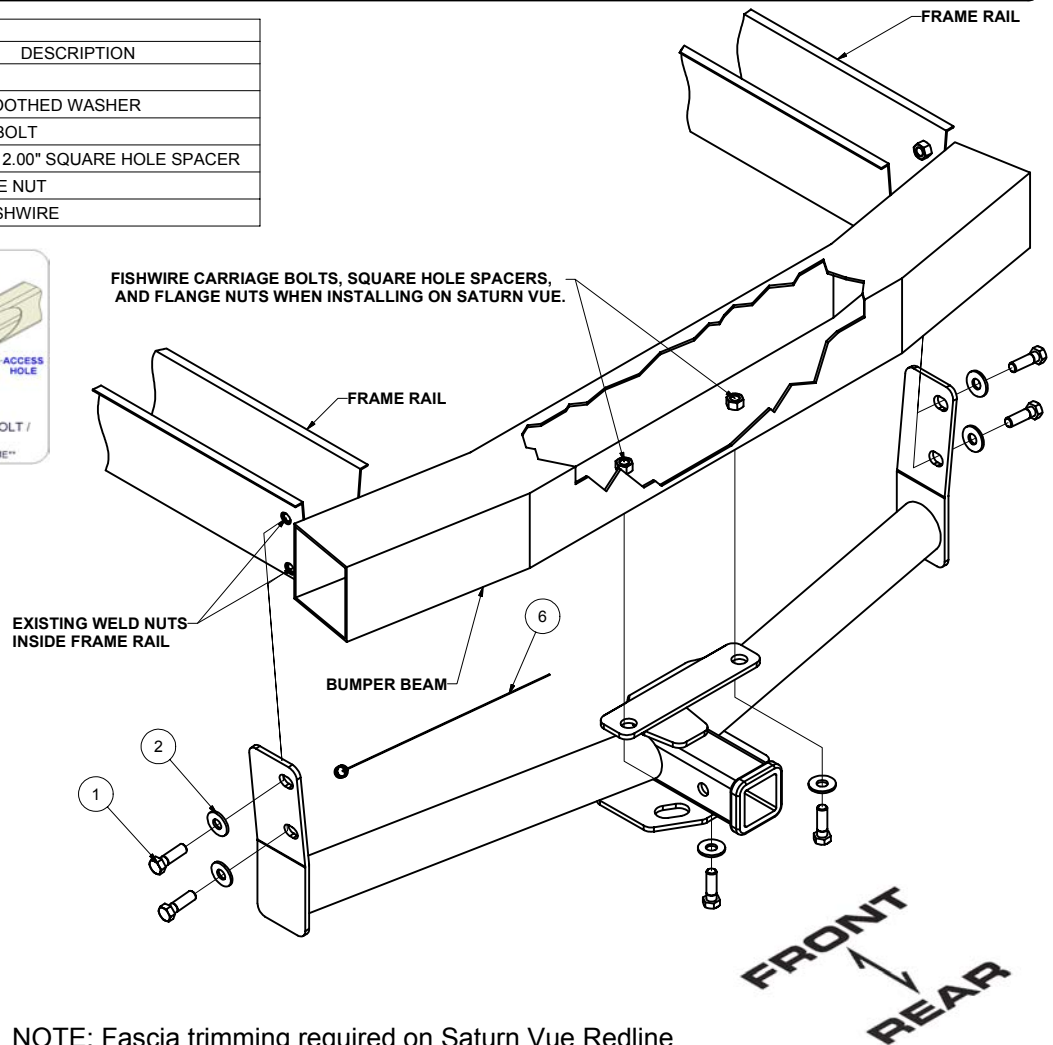

NOTE: Fascia trimming required on Saturn Vue Redline

INSTALLATION STEPS

1. On the Chevy Equinox and the GMC Terrain, it is necessary to remove the panel at the center of the fascia to provide space for hitch installation. (Return the panel to vehicle owner.)
2. Remove existing M12 fasteners from outside surfaces of frame rails. If present remove tie down brackets and return to customer.
3. Raise hitch into position and fasten to bumper beam using M12 bolts and conical washers.
4. Install M12 bolts and conical washers on outside surfaces of frame rails.
5. Fishwire remaining carriage bolts and square hole spacers through end of bumper beam
6. Torque all M12 hardware to 62 ft-lbs. Torque all 1/2" hardware to 75 ft-lbs.

PERIODICALLY CHECK THIS RECEIVER HITCH TO ENSURE THAT ALL FASTENERS ARE TIGHT AND THAT ALL STRUCTURAL COMPONENTS ARE SOUND.

Curt Manufacturing Inc., warrants this product to be free of defects in material and/or workmanship at the time of retail purchase by the original purchaser. If the product is found to be defective, Curt Manufacturing Inc., may repair or replace the product, at their option, when the product is returned, prepaid, with proof of purchase. Alteration to, misuse of, or improper installation of this product voids the warranty. Curt Manufacturing Inc.'s liability is limited to repair or replacement of products found to be defective, and specifically excludes liability for incidental or consequential loss or damage.

78275 / RRH13591