

WARNING!! Brake, fuel and electrical lines may need to be loosened or repositioned to provide clearance for new hardware.

(Notes:) The heat shields located above the rear axle and gas tank must be cut out or removed to install the Quick Goose. To ease installation on four wheel drive Dodge applications the fender liners can be removed and replaced when the process is complete.

Installing Quick Goose

- 1) Position the Quick Goose over the rear axle and up to the rear cross arm with the cylinder facing the rear of vehicle. Place the four 5/8" x 1 3/4" carriage bolts into the Quick Goose first, then through the rear cross arm placing the 5/8" flange nuts on the bolts finger tight.
- 2) Move the front cross arm to the Quick Goose and place the 5/8" x 1 3/4" carriage bolts into the cross arm and then through the Quick Goose. Use the 5/8" flange nut to secure in place.
- 3) Torque all the 5/8" hardware to 150LBS.

Installing Ball

- 1) From the inside of pick-up bed place the chrome ball down into the cylinder. Place the chrome ring over the ball and install six allen head screws into the ring and cylinder.

Installing Handles

A notch must be cut in the fender wall between the bed supports to provide operating clearance for the Quick Goose rods. Replace fender liner if previously removed and cut away the section in front of the notch.

- 1) Before installing handles, insert 5/32" roll pin into red rod (Lock) handle (see detail B).
- 2) Place the ball lock in the cylinder slot as shown.
- 3) Place the red handle through the fender wall notch and into the left side rod guides of the Quick Goose, Pushing it about 3/4 of the way into the cylinder. Use the spring provided and place it between the rod guide and the ball choker slowly slide the handle through the spring to stabilize it. Push the handle into lock and secure with 1/4" bolt and nylock nut.

Apply the ball locked label on rod near a reference point in the fender well.

- 4) Place rod lock over ball actuating rod before installing. Place the black handle through the fender wall notch and into the left rod guides pushing it all the way forward. Pull the pre-assembled linkage lever to the rod and place a 1/4" bolt thru the handle and linkage lever attachment holes. Use a nylock nut to secure in place.

Installing Safety Chain Attachments

- 1) From inside the truck box place the safety chain attachments through the pre-drilled holes in the bed of truck.
- 2) From under the vehicle place flatwashers, two springs and 5/8" jam nuts on each u-bolt.
(Note: Washers must be mounted as shown on sheet 2)

Caution!!!

- 1) Check that all 5/8" hardware has been torqued to 150ft.LBS (12-5/8" Flange Nuts total)
- 2) Check that all side plate hardware has been torqued. Some hardware listed will not apply to your application.
 - 3/8" to 30ft.lbs
 - 1/2" to 75ft.LBS
 - 5/8" to 150ft.LBS
 - 3/4" to 250ft.LBS
 - 1" to 250ft.LBS
- 3) Check that all fasteners are secure.
- 4) Re-attach Brake, Fuel and Electrical lines so they do not contact any of the added fasteners.

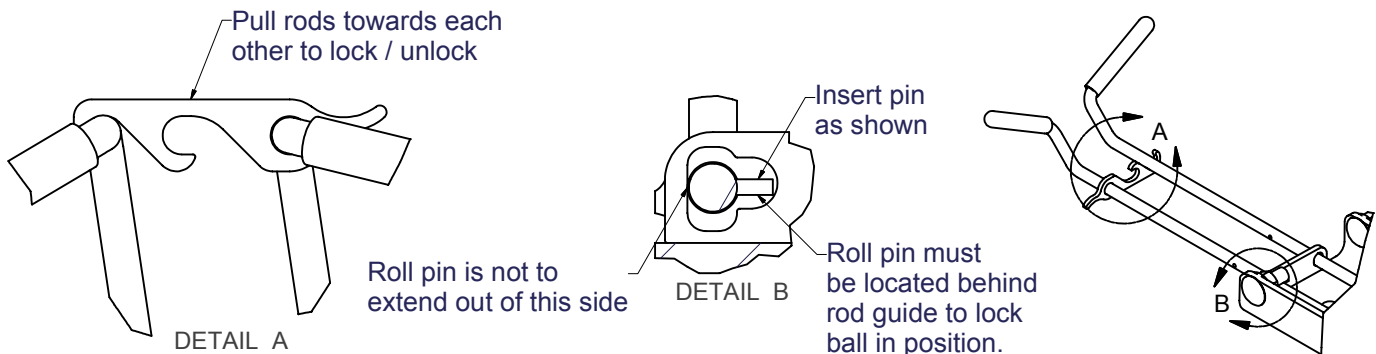

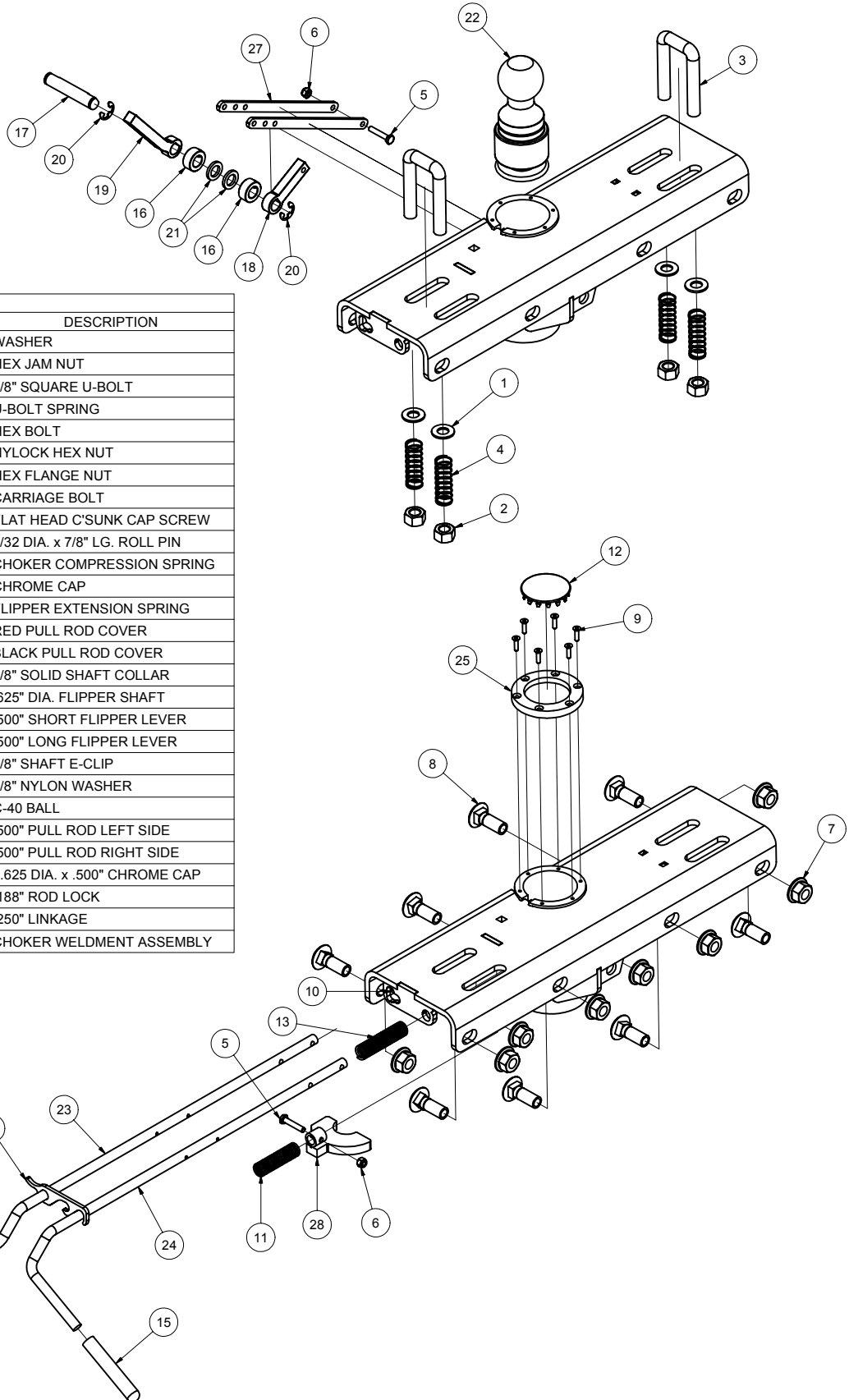

Parts List

ITEM	QTY	PART NUMBER	DESCRIPTION
1	4	9/16"	WASHER
2	4	5/8-18	HEX JAM NUT
3	2	CM-C113-UB	5/8" SQUARE U-BOLT
4	4	CM-C113-UBS	U-BOLT SPRING
5	2	1_4 - 20 x 1 3_8 HEX	HEX BOLT
6	2	1_4 - 20	NYLOCK HEX NUT
7	8	5/8-11	HEX FLANGE NUT
8	8	5/8-11 x 1 3/4	CARRIAGE BOLT
9	6	#10-32 x 3/4	FLAT HEAD C'SUNK CAP SCREW
10	1	64101	5/32 DIA. x 7/8" LG. ROLL PIN
11	1	CM-LC-072J-12MW	CHOKER COMPRESSION SPRING
12	1	C-127	CHROME CAP
13	1	CM-LE-093G-7MW	FLIPPER EXTENSION SPRING
14	1	CM-C40-109	RED PULL ROD COVER
15	1	CM-C40-108	BLACK PULL ROD COVER
16	2	33375	5/8" SOLID SHAFT COLLAR
17	1	CM-C40-FL1	.625" DIA. FLIPPER SHAFT
18	1	CM-C40-FL2	.500" SHORT FLIPPER LEVER
19	1	CM-C40-FL3	.500" LONG FLIPPER LEVER
20	2	68083	5/8" SHAFT E-CLIP
21	2	76067	5/8" NYLON WASHER
22	1	CM-40-BALL	C-40 BALL
23	1	CM-C40-PRL	.500" PULL ROD LEFT SIDE
24	1	CM-C40-PRR	.500" PULL ROD RIGHT SIDE
25	1	CM-C40-CP	3.625 DIA. x .500" CHROME CAP
26	1	CM-C40-RL	.188" ROD LOCK
27	2	CM-C40-L	.250" LINKAGE
28	1	CM-C40CH-WA	CHOKER WELDMENT ASSEMBLY

C-40 OPERATION

1. To raise ball into towing position, pull the red(right side) handle. (Be sure ball locked label on rod is at designated reference point)
2. Release the handle to lock the ball. (The ball is properly engaged when the inspection groove is visible above chrome ring and rod roll pin is behind rod guide)
3. To lower ball pull and hold the red handle out then pull the black handle. When the ball is completely down release the red handle to lock the ball down.

C-40 INSTALLATION CHECK

Raise the hitch ball into position with the locking plate engaged. Connect the trailer to the hitch ball. Check clearance. You should have 6" minimum clearance between bottom of the trailer overhang and top of the bed sides. Verify clearance between lower front of trailer and corner of bed or bumper and between the upper front corner of the trailer and rear of cab.

Maintenance

1. Keep hitch ball lubricated. Use silicone or equivalent spray to prevent wear and rust in cylinder.
2. Lubricate all moving parts once a month.
3. Keep hitch assembly free of dirt and other foreign matter. (Use cover provided when not in use)
4. Check tightness on **ALL** fasteners before each use.
5. Inspect ball and all moving parts for wear before each use. **Do not tow trailer with worn or damaged parts.**

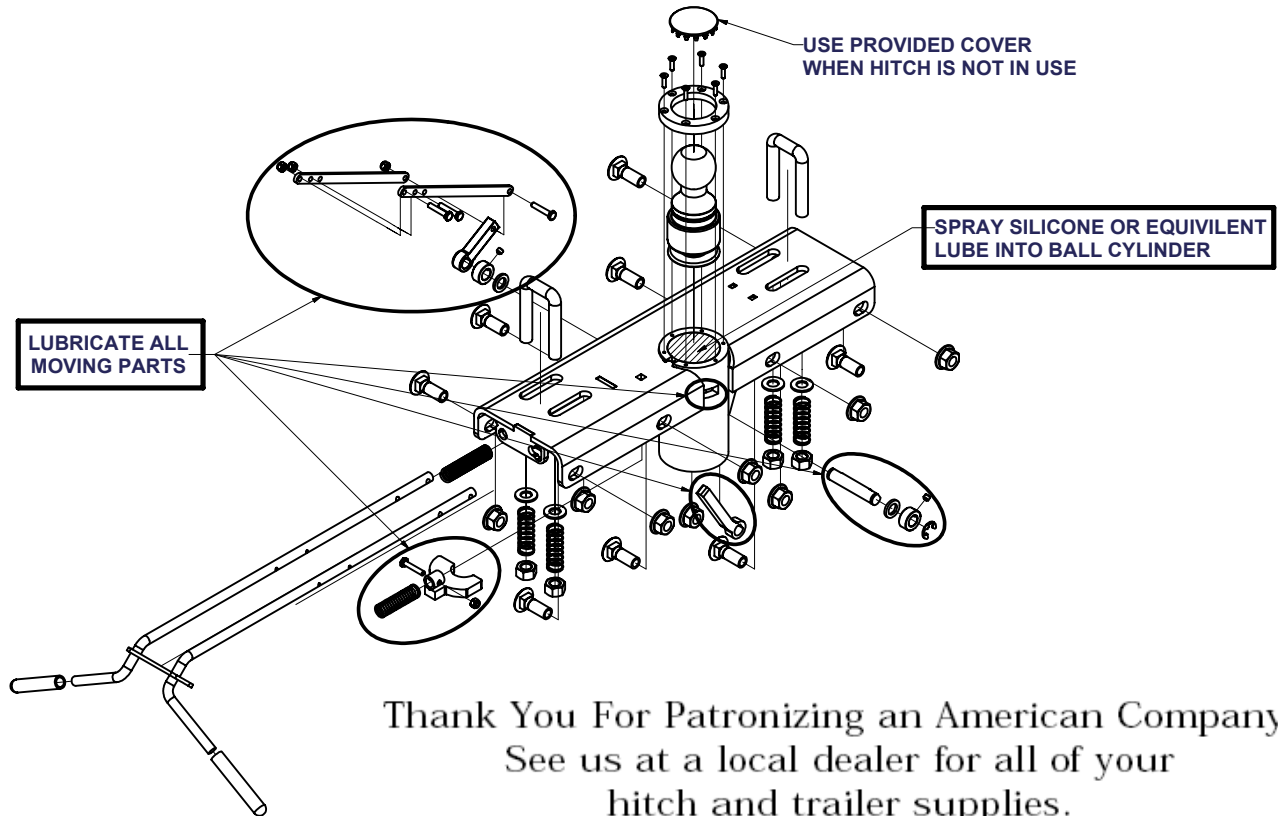

Thank You For Patronizing an American Company.
See us at a local dealer for all of your
hitch and trailer supplies.

**MADE
IN THE
U.S.A.**



PERIODICALLY CHECK THIS HITCH TO INSURE THAT ALL FASTENERS ARE TIGHT AND THAT ALL STRUCTURAL COMPONENTS ARE SOUND.

Curt Manufacturing Inc., warrants this product to be free of defects in material and/or workmanship at the time of retail purchase by the original purchaser. If the product is found to be defective, Curt Manufacturing Inc., may repair or replace the product, at their option, when the product is returned, prepaid, with proof of purchase. Alteration to, misuse of, or improper installation of this product voids the warranty. Curt Manufacturing Inc.'s liability is limited to repair or replacement of products found to be defective, and specifically excludes liability for incidental or consequential loss or damage.